

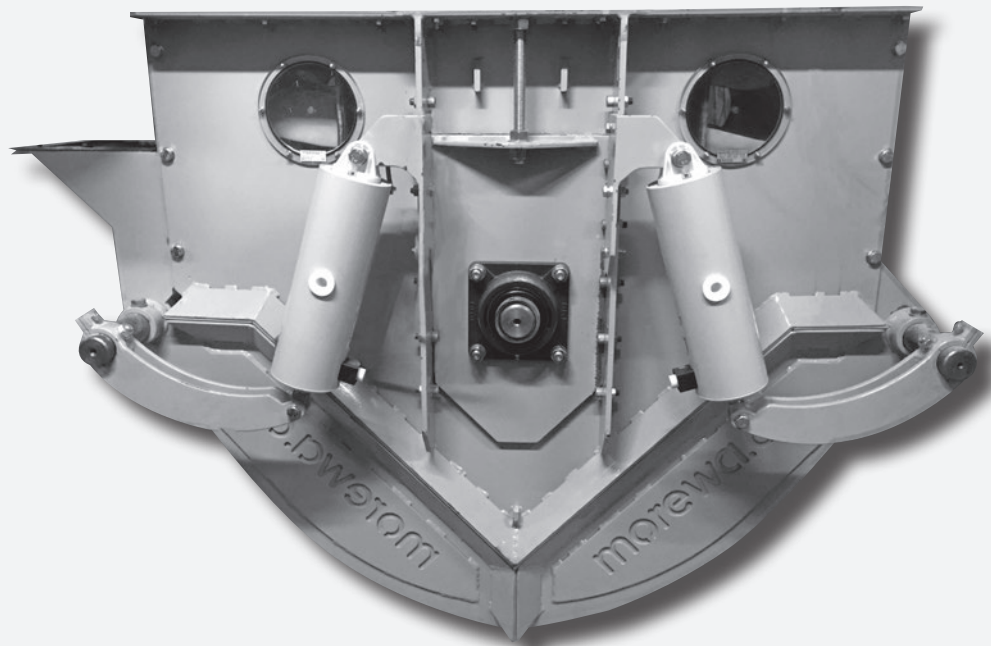

# High-performance elevator



This belt and bucket elevator are suitable for the vertical transport of bulk materials such as grain, mixed feed, pellets, oilseeds, etc. It lifts up to 1400 tons per hour with a height difference of up to 80m. These high-performance capacities are particularly appreciated by experts. The elevator is used in silos, processing plants and port terminals.

## The advantages

- easy handling thanks to column-free elevator foot
- Robust and reliable labyrinth seal
- linear actuator enables clean and fast residual emptying
- Personal protection by dead man's switch
- Monitoring of the discharge valve caps

As specialized mill builders, we can individually adapt the operation of your elevator to your operating conditions, height and production situation. Our highly efficient team works in 24 hours a day, 7 days a week. We want to be operational when you lose the smallest production time. Thanks to our central location directly on the A1, we are within reasonable distance for every mill.

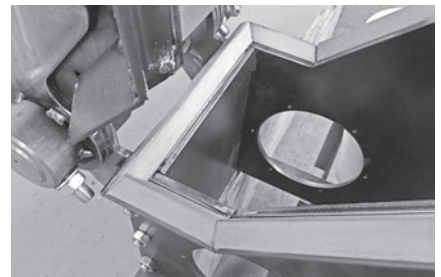

## Morewa AG

Mühliacherweg 20  
CH-5105 Auenstein

Tel. +41 (0)62 897 28 55  
Fax +41 (0)62 897 31 41

www.morewa.ch  
info@morewa.ch



**+ High operational safety**

Integrated stop and scroll monitors keep operation safe and trouble-free.

**+ High longevity**

Proven machine elements and wear-resistant materials guarantee long service life, durability and high reliability. Special wear protection devices are optionally available for inlet, foot and head.

**+ Low maintenance**

The elevator head with divided hood simplifies the support. Cleaning openings and the clamping shaft facilitate accessibility.

